

Product design meets OHSAS requirements (Ref: Work instructions DOC No.WI/10/ENG001). ALL DIMENSIONS ARE IN mm & WEIGHTS ARE IN kg UNLESS OTHERWISE SPECIFIED. FORMAT No.: Meeh003/R0

ALL INFORMATION CONTAINED IN THIS DOCUMENT IS CONFIDENTIAL AND THE PROPERTY OF TOSHIBA TRANSMISSION & DISTRIBUTION SYSTEMS (INDIA) PVT. LTD. REPRODUCTION OF THIS IN ANY FORM IS TO BE DONE WITH THE SPECIFIC PERMISSION OF THE ORGANISATION.

1 2 3 4 5 6 7 8

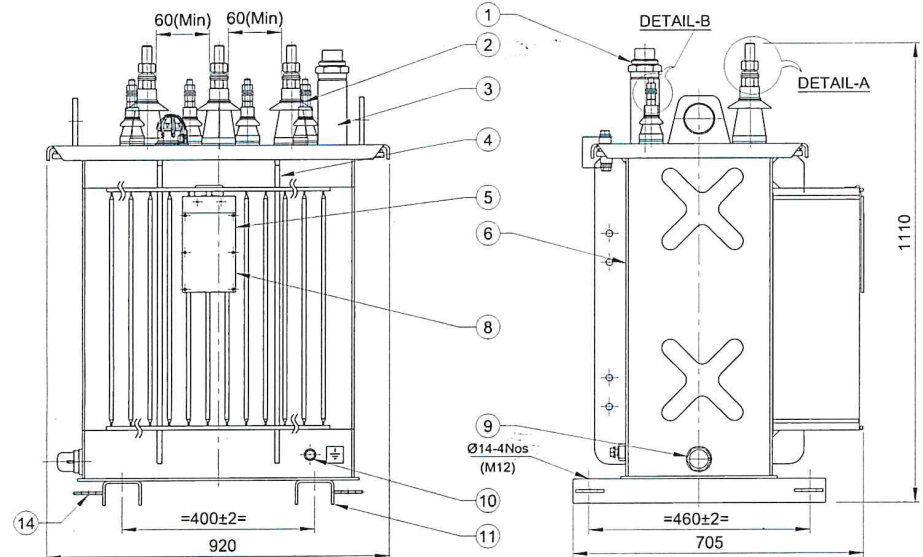

- NOTE:-**
1. FINISH PAINT SHADE: RAL 7035 (LIGHT GREY).
 2. OVERALL DIMENSIONS & WEIGHTS ARE SUBJECT TO ±10% TOLERANCE.
 3. THE POSITION, LOCATION, DESIGN OF FITTINGS & ACCESSORIES MAY SLIGHTLY VARY DURING MANUFACTURING.
 4. COMPLETE TRANSFORMER WITHSTANDS LOWER LIMIT OF AMBIENT TEMPERATURE -40°C .
 5. RATING PLATE SHALL BE PROVIDED ONLY ON HV SIDE AND ONE ADDITIONAL RATING PLATE FIXING PROVISIONS ARE PROVIDED.
 6. TIGHTENING TORQUE
 - LV & HV BUSHING STEM(OUTSIDE) - 13Nm.
 7. TERMINAL MARKING AND EARTHING SYMBOL SHALL BE PAINTED WITH BLACK COLOUR.
 8. OIL LEVEL MARKING SHALL BE VISIBLE FROM TANK SHORTER SIDE
 9. GAP (2mm) SHOULD MAINTAIN BETWEEN TWO ADJACENT NUTS AS PER DETAIL-A & DETAIL-B

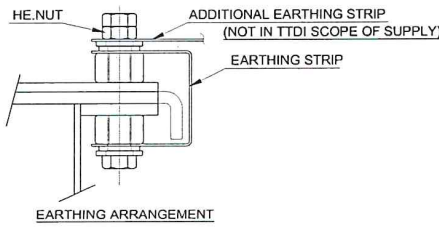
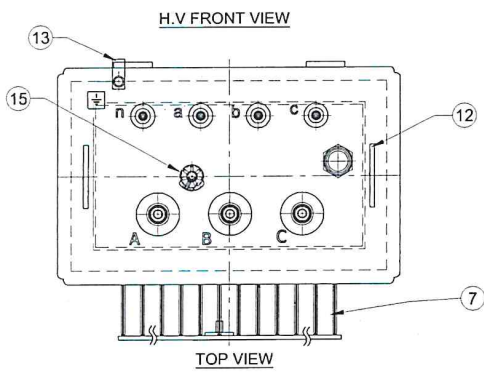
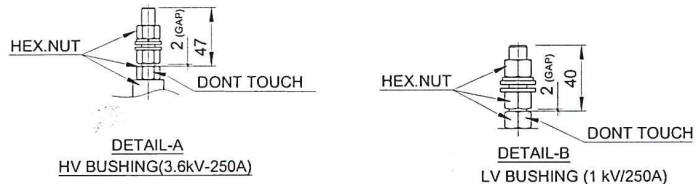

S.NO	DESCRIPTION	QTY.
15	TAP SWITCH	1
14	TOWING EYES	4
13	EARTHING STRIP BETWEEN TANK AND TOP COVER	1
12	LIFTING LUGS FOR LIFTING OF TRANSFORMER	2
11	BASE CHANNEL FORMED	2
10	EARTHING TERMINALS	2
9	OIL DRAINING CUM SAMPLING DEVICE	1
8	RATING PLATE FIXING BRACKET	1
7	CORRUGATION PANEL	1
6	NAME OF THE MANUFACTURER (MONOGRAM)	1
5	RATING PLATE	1
4	VERTICAL STIFFENER	-
3	L.V. BUSHINGS(1.0kV/250A)	4
2	H.V BUSHINGS(3.6kV/250A)	3
1	OIL FILLING PIPE WITH VERTICAL FLOAT OLG	1

TOTAL WEIGHT OF TRANSFORMER (kg)	RATING KVA	VOLTAGE(V)		CURRENT(A)	
		PRIMARY	SECONDARY	PRIMARY	SECONDARY
670	100	1000	410	57.735	140.817

REV	ZONE	DATE	MODIFICATION	MODIFIED	CHECKED	APPRD.
				NAME	DATE	

Minimum External Air Clearances	
	HV
Phase to Phase	60
Phase to Earth	60

NO OF PHASES : 3

COOLING : ONAN

FREQUENCY : Hz 50

TEMP.RISE O / W : 60/65°C

CONNECTION GROUP : Dyn11

SPECIFICATION : IEC 60076 & EN 50588/EN 50708-2

TOSHIBA

TOSHIBA TRANSMISSION & DISTRIBUTION SYSTEMS (INDIA) PVT. LTD.
DISTRIBUTION TRANSFORMERS DIVISION

SCALE: NTS

OUT LINE GENERAL ARRANGEMENT FOR
100 kVA, 1/0.41 kV TRANSFORMER

DESIGNED	<i>R. Srinivasan</i>	15/12/21
DRAWN	<i>A. Karthikeyan</i>	15/12/21
CHECKED	<i>R. Srinivasan</i>	15/12/21
APPROVED	<i>R. Srinivasan</i>	15/12/21

PRJ.NO. 08273 M
DRG.NO. 3 OG 86625
SHT.NO. 1 OF 1 | R 0

HERMETICALLY SEALED COMPLETELY FILLED - (TIER-2)

TOSHIBA	Toshiba Transmission & Distribution Systems (India) Pvt.Ltd. Distribution Transformers Division	Engineering
		Unit-10

GUARANTEED TECHNICAL PARTICULARS THREE PHASE DISTRIBUTION TRANSFORMER					
Enquiry No : 10889		Customer : KKM POWER Oy, Finland			
kVA : 100	kV :1/0.41	Phase : 3	Freq. : 50Hz	Cooling : ONAN	Doc No:
Sl. No.	Description	UNIT	100 kVA		
1)	Make		Toshiba Transmission & Distribution Systems (India) Pvt. Ltd		
2)	Type		Hermitically Sealed		
3)	Phases	No.	Three		
4)	Rating	kVA	100 kVA		
5)a)	Rated Voltage:				
	HV	V	1000		
	LV	V	410		
b)	Highest voltage for equipment	kV	1.0		
6)	HV Tapping Range		+5% to -5% insteps of 2.5%		
7)	Frequency	Hz	50		
8)	Vector Group		Dyn11		
9)	Insulation Level				
	HV	kV peak	Not Applicable		
	LV	kV peak	Not Applicable		
10)	Power Frequency Level				
	HV	kV rms	10		
	LV	kV rms	3		
11)	Winding material		Aluminium		
12)	Core Material		CRGO		
13)	Temperature Rise:				
	Oil	°C	60		
	Winding	°C	65		
14)	Losses				
	No Load Losses at rated Voltage and Frequency	Watt	130 (MAX)		
	Load Losses at 75 °C	Watt	1250 (MAX)		
15)	Impedance Voltage	%	4% (+/- IEC Tolerance Applicable)		
16)	Percentage Resistance	%	1.25		

"ALL INFORMATION CONTAINED IN THIS DOCUMENT IS CONFIDENTIAL AND THE PROPERTY OF TOSHIBA TRANSMISSION & DISTRIBUTION SYSTEMS (INDIA) PVT. LTD., REPRODUCTION OF THIS IN ANY FORM IS TO BE DONE WITH THE SPECIFIC PERMISSION OF THE ORGANIZATION"

TOSHIBA		Toshiba Transmission & Distribution Systems (India) Pvt.Ltd. Distribution Transformers Division		Engineering
				Unit-10
17)	Regulation at:			
	Full Load UPF	%		1.32
	Full Load 0.8 PF	%		3.31
18)	Efficiency at 0.8 PF:			
	Full Load	%		98.3
	¾ Full Load	%		98.63
	½ Full Load	%		98.91
19)	Terminal Arrangement:			
	HV			Bare Bushings – Porcelain (3.6kV/250A) Reference standard : DIN 42539
	LV			Bare Bushings – Porcelain(1kV/250A) Reference standard : EN 50386
20)	Actual Overall Dimensions:			
	Length	mm		900
	Width	mm		685
	Height	mm		1300
21)	Overall Weight			
	Total Weight	Kg.		680
22)	Noise Level	LwA dB (A)		As per NEEMA TR1
Applicability of Optional Fittings For this sale order				
23)	Rollers			No
24)	Provision For Pole Mounting consoles			Yes
25)	HV flags/connector/lug			No
26)	LV flags/connector/lug			No
27)	HV Tapping/Tap Switch			Yes
28)	Over pressure valve			No
29)	Thermometer pocket			No
30)	Surge arrester holders			No

Note:

- Actual overall dimensions and weights are subjected to +/-10% Tolerance
- All the efficiencies and regulations are calculated at the nominal values of NLL, LL AT 75DegC and % Z at 75 Deg C.
- If HV/LV flags required transformer overall height will increase.
- Paint: Class C4 corrosion protection paint will be provided instead of hot dip galvanizing.**

TOSHIBA	Toshiba Transmission & Distribution Systems (India) Pvt.Ltd. Distribution Transformers Division	Engineering
		Unit-10

5. No load current is max 2% of full load current at rated voltage.